



1. INTRODUCTION

- 1.1. The Scottish Fire and Rescue Service (SFRS) encompasses a diverse and growing environment for partners including the care sector, businesses, heritage and industry where we welcome residents, tourists and commuters alike to our non-domestic premises. Such premises and workplaces fall within the scope of the [Fire \(Scotland\) Act 2005](#) and its associated Regulations and are deemed “Relevant Premises”. Persons responsible for such premises are termed “Dutyholders” and are required to ensure adequate fire safety measures are provided within them. This process is achieved through the undertaking of an appropriate Fire Safety Risk Assessment.
- 1.2. SFRS are the Enforcing Authority for the majority of Relevant Premises within Scotland and have a legal responsibility to ensure advice and guidance is given to Dutyholders and where required, enforce compliance with the legislation.
- 1.3. It is not the responsibility of SFRS to undertake a fire safety risk assessment within these premises. That role rests with the Dutyholder(s) who may be the Owner, Employer, Manager, Factoring Agent or indeed all of those.
- 1.4. This Local Enforcement Delivery Plan (LEDP) sets out City of Glasgow’s risk based inspection programme for the delivery of enforcement activities by our Fire Safety Enforcement Officers (FSEOs) and Auditing Officers (AOs) in accordance with the [SFRS Fire Safety Enforcement Policy Framework](#) (FSEPF).
- 1.5. Using this approach, we will ensure that the service we deliver is driven by consultation, in line with SFRS expectations and prepares our staff to safely, effectively and efficiently support the communities we serve.
- 1.6. This LEDP will be subject to regular review and be adaptable to meet local needs as new risks emerge and the Service further develops its enforcement strategies. It aims to communicate the clear intention of how the FSEPF will be delivered locally to achieve the agreed published goals and will concentrate on the following undertakings:

- *Routine Fire Safety Audits*
- *Post Fire Audit Response*
- *Locally identified themes following fire activity or intelligence received*
- *Thematic activities informed by the Prevention, Protection and Preparedness (PP&P) Directorate*
- *Significant event planning and preparation*
- *Continued resource planning*

2. STRUCTURE

2.1. Within City of Glasgow Local Senior Officer (LSO) Area, a Group Commander oversees the direction and implementation of Prevention, Protection and Preparedness and is supported by a Station Commander who has a remit for the delivery and supervision of the Fire Safety Enforcement team.

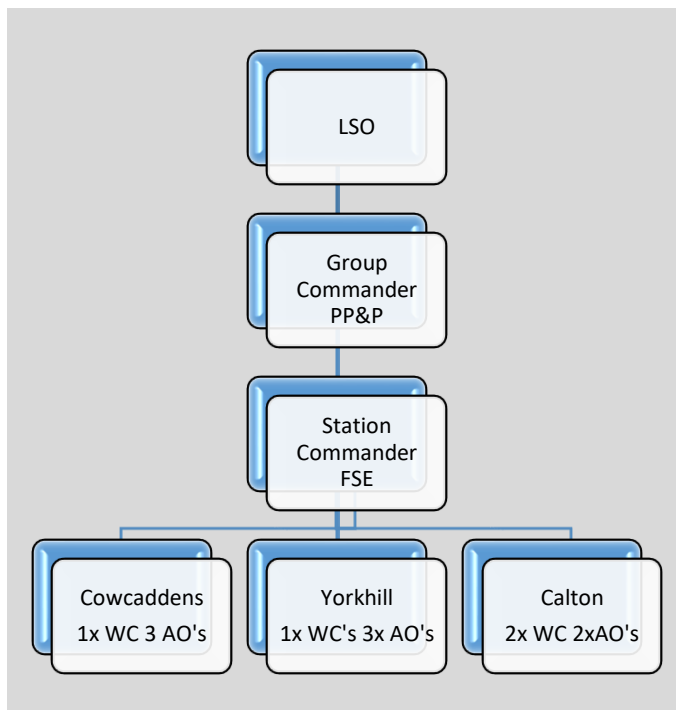

PLEASE NOTE: Above structure is currently under review. As of April 2024

- Cowcaddens 1x WC, 3x AO posts
- Yorkhill 1x WC, 3x AO posts
- Calton 2x WC, 2x AO post (1x AO post job shared)

In addition:

- 6 month pilot – WC - FSE Support Role based at HQ (seconded from Yorkhill FS Office).

2.2 Group and Station Commanders with an enforcement responsibility, undertake several roles within LSO Management Structures. They have a responsibility to coordinate the delivery of enforcement through FSEOs and AOs and provide a conduit between the LSO areas and the PP&P Directorate to ensure quality, consistency and policy is being achieved.

2.3 To enable enforcement activities to be effective and efficient, it is important to make the best use of the resources available, provide a clear direction for all to follow, identify achievable targets to work towards in accordance with perceived risk and most importantly communicate this to all relevant parties.

2.4 This LEDP relates to all audit activity and will require the support of all FSEOs and AOs to ensure the optimum delivery and benefits of the plan are realised. It will focus on the main areas outlined above, concentrating on the types of enforcement work to fulfil the FSEPF. As these roles require specialist skills, early succession planning required by local managers is vital to adequately resource and train new personnel in the role.

2.5 Quality Assurance will be undertaken by the PP&P Directorate or in some circumstances, alternative LSO Areas to promote a continuous improvement culture and provide evidence towards measuring FSE performance within each respective LSO area.

3. RESPONSIBILITIES

3.1 The PP&P Group Commander will be responsible for the production, monitoring and review of the LEDP to meet FSEPF commitments and area risks, the performance management and coordination of FSE activities and the reporting of progress to the LSO and PP&P Directorate.

3.2 PP&P Station Commanders will be responsible for planning FSE activities, which support this plan, liaising with the PP&P Directorate, and the Quality Assurance and performance management of FSEOs and AOs.

3.3 FSEOs and AOs will be responsible for delivering against this plan by engaging with and supporting Dutyholders, monitoring audit outcomes and informing their Station and Group Commander at an early stage of non-compliance relating to formal enforcement action. This may involve gathering evidence to support the preparation of reports to the Crown Office and Procurator Fiscal Service.

4. AUDIT ACTIVITIES

4.1. All audit activities within the City of Glasgow LSO area will be risk based, with resources being directed and prioritised around 4 key areas:

- *Premises where the risk to life from fire is greatest*
- *Emerging intelligence e.g. through operational activity or partner communications*
- *A risk based methodology outlined by the Directorate*
- *Post fire audit and analysis*

4.2 As part of the risk based methodology set by the PP&P Directorate, any program set by areas must include the following core activity:

- *Ensure that all Care Home Services, Hospitals, Private Hospitals and Hospices which provide inpatient care are audited annually*
- *Ensure that newly registered Care Home Services are audited within seven working days of becoming operational*
- *Undertake annual audits of Hotel and Hostel premises where previous activity has identified a calculated risk level of "medium and above" and a management compliance level of 3 or more until improvements have been demonstrated and a management compliance level of 2 or less achieved*
- *Undertake annual audits of all other premises where previous activity has identified a calculated risk level of "High" or "Very High" and a management compliance level of 3 or more until improvements have been demonstrated*
- *Plan to undertake HMO audits in line with the [SFRS Houses in Multiple Occupation \(HMO\) Auditing Policy](#)*
- *Ensure relevant premises identified as having had a fire, or other significant fire safety event, will have an audit undertaken at the earliest opportunity to determine whether the incident was initiated due to inadequate fire safety measures or failure within the fire risk assessment process*
- *Undertake an initial or follow up audit as a result of meeting the criteria within Stage 3 of the [SFRS Unwanted Fire Alarm Signals \(UFAS\) Incident Procedure](#)*

- *Continue to monitor and work in conjunction with Dutyholders where areas of non-compliance have been identified and action plans have been requested, to ensure that appropriate methods of resolution are being undertaken*
- *Where necessary, seek formal compliance of fire safety legislation by proportionate use of all available enforcement powers under the FSA*

4.3 The area will also analyse previous audit outcomes, Operational Reassurance Visit data, fire activity and other intelligence sources to identify additional premises types which may be demonstrating an increased risk and not covered above, for inclusion within this delivery plan.

4.4 [Appendix A](#) contains the proposed delivery plan incorporating the above, with reference to the FSEPF, for the forthcoming period.

5. AUDIT PROCESS

5.1 The principles that FSEOs and AOs must adhere to are laid out within the [Scottish Regulators' Strategic Code of Practice](#). In addition, the model laid out within the [Health & Safety Enforcement Management Model](#) (EMM) will be followed when deciding audit outcomes following a visit.

5.2 FSEOs and AOs are expected to be professional and courteous when engaging with Dutyholders and undertaking audits and must be mindful of conveying a positive image of the service at all times.

5.3 Audit appointments will be arranged by telephone, by issuing a standard letter detailing the date and time of the audit, and what the audit will entail. Dutyholders will also be informed of the likely documentation that will be inspected to allow them to have this collated in advance. Should the time or date not be suitable, contact details are provided so a mutually agreed time can be arranged.

5.4 The audit will commence with the FSEO or AO showing their identification, and asking to speak with the Dutyholder or other appropriately nominated person that can facilitate the audit. This can often be the Fire Risk Assessor, General Manager, Owner of the building or another person nominated for the responsibility of overall fire safety within the premises.

5.5 A discussion and audit of documentation should cover aspects such as the fire safety arrangements in place, the contents of the fire risk assessment (including any outstanding actions arisen from its findings), training (including evacuation), maintenance of fire systems and any fire history or false alarms and unwanted fire alarm signals (UFAS).

5.6 An inspection of the premises will be undertaken to compare the fire safety risk assessment findings against the hazards and measures in place at the time of the visit. The detail of the inspection will depend on a number of factors including size, age, access and overall management of the building. It is important that a nominated person be available to assist the FSEO or AO, to provide access to restricted or locked areas and to advise on any health and safety issues particular to the building that may be relevant to the inspection.

5.7 It is likely the process should last between 1.5 and 3 hours although this is a rough guide. At the end of the inspection, the FSEO or AO will summarise the findings of the inspection with the responsible person and ensure they fully understand what they are required to do to remedy any deficiencies relating to fire safety. This will be followed up in writing by the officer at the earliest opportunity. Contact details will be provided to the Dutyholder so that they can clarify points or raise concerns following the audit, if necessary.

- 5.8 On some occasions, the findings of the audit may result in the need for an action plan to be drawn up and proposed for agreement with the FSEO or AO. The officer will explain what this entails and engagement shall continue to ensure progress throughout the period of that plan.
- 5.9 Occasionally, formal enforcement action will be necessary e.g. an Enforcement Notice requiring works to be undertaken within a specified time-period or a Prohibition Notice prohibiting/restricting the use of the premises (or part of the premises) due to serious and imminent fire safety concerns which pose a risk to life. The officer will fully discuss the implications of any Notice and the process of appeal will be outlined in any correspondence.
- 5.10 The FSEO or AO will fully explain the reasons for any need to improve fire safety measures within the premises and will consider the level of risk against the sacrifice involved in terms of time, effort and expense to implement those measures. In the event of a failure to agree, a Dutyholder can initially raise their concerns with the local PP&P Manager who will review the situation and, where appropriate, suggest a resolution. Where concerns remain, the Dutyholder will be given contact details for the PP&P Directorate who will further review the situation and advise accordingly. In the event that disagreement remains, the Dutyholder can [raise a dispute](#) with [His Majesty's Fire Service Inspectorate](#) for Scotland who will undertake an independent review.

6. QUALITY ASSURANCE

- 6.1 All audits undertaken will follow a process of quality assurance. This is generally actioned by the Station Manager who will process the completed audit on an electronic system. However, occasionally the local PP&P manager may request support from the Directorate and an independent review may take place. The findings of the audit will be assessed and discussed with the FSEO or AO concerned.
- 6.2 The Directorate may periodically peer review (or instruct other LSO areas to peer review) audits to maintain a consistent approach and to share good practice throughout SFRS. The findings will be fed back to all LSO areas to promote effective and consistent delivery across the enforcement function.

7. PERFORMANCE REPORTING

- 7.1 The PP&P Group Commander will produce a report against this LEDP and present this to the SFRS PP&P Local Managers Meeting on a quarterly basis. This will provide an update of progress against the clear targets laid out within the plan detailed below, and ensure that the area continues to support those premises deemed at highest risk.
- 7.2 The report will also provide an update to the LSO on any changes or intelligence that has affected the plan, and enable the LSO to report progress to the Community Planning Partnership as part of the Local Area Plan.
- 7.3 The report will also be tabled at the LSO Management Meetings and discussed as part of the area liaison and performance management meetings with the Directorate.

APPENDIX A – LOCAL ENFORCEMENT DELIVERY PLAN

CoG LSO Area Local Enforcement Delivery Plan 2024/2025 Expected Audit Activity

Premises Type / Audit Type	Number of Premises	Number of Buildings	Framework Premises	Q1	Q2	Q3	Q4	Completed YTD	Commentary
Care Homes	116	Approx 125	Yes						
Hospitals	21	?	Yes						
Prisons	1	Unknown	No						
Hotels: MCL 3 and VH	1	1	Yes						
Hotels: MCL 3 and H	0	0	Yes						
Hotels: MCL 3 and M	1	1	Yes						
Previous MCL 3 and VH	0	0	Yes						
Previous MCL 3 and H	0	0	Yes						
HMO (as per Policy) Max % quoted	?*	?	Yes						*Not easy to predict, awaiting volume of new applications and renewals (based on risk history – Approx 500)
Post Fire Audit*	100	100	Yes						
All other H & VH	30	30	Yes						
All other due list work	150	150	No						
FSE Notification from Ops*	15	15	Yes						
Complaint*	15	15	Yes						
UFAS Stage 3 Audit*	?*	?	Yes						UFAS to be dealt with prior to meeting stage 3 trigger. Unable to predict a number.
Thematic*	75	75	No						SFRS TAP premises, Public Houses, Theatres, Nightclubs, large music venues, Premises selling/storing Fireworks (Risk Based) Hotels out with Framework
Total Number of Identified Risks	Unknown	Unknown							

*Based on previous year figures

Formal Action Taken

Enforcement Activity	Previous year activity	Q1	Q2	Q3	Q4	Total	Commentary
<u>Statutory Notices</u> Enforcement notice (EN) Prohibition notice (PN) Alteration notice (AN)	EN = 3 PN = 1 AN = 0						

Local Initiatives Planned

Other Work	Initiatives	Commentary / Outcome
Q1		
Q2		
Q3		
Q4		